



Specifications

Reflectors - Precision formed, high performance, 95% total reflectance, segmented optics utilizing Alanod MIRO® 4 specular aluminum warranted for 25 years. Reflector optics are available in a wide variety of photometric distributions and spacing criteria.

Construction - Channel, ends and socket brackets are manufactured from 22-gauge cold rolled steel. Riveted and screwed assembly. Tool-less ballast and wiring access.

- Optional all aluminum construction. Specify AL.

Lamp Shielding - Lamp shielding options are provided with a 22ga. premium polyester powder coat finish door frame with two painted hinges and two painted opposing rotary cam latches. Lenses are held in place with lens clips. Fixture is provided with double gasketing around door frame and lens.

Finish -

- Standard premium polyester powder coat finish, utilizing a 7-stage pretreatment process of iron phosphate, a non-chromium sealer and a de-ionized water rinse to provide superior adhesion and corrosion resistance.

Ballasts - All standard ballasts are electronic, energy saving, thermally protected, Class-P, HPF, non-PCB, Sound Rated A, UL/CSA certified where applicable and comply with © Federal Ballast Law (Public Law 100-357, 1988). Default ballast configuration is for two-lamp ballasts.

Electrical - UL listed wire, rated for required temperatures, used throughout. Lamps are secured with rotary locking lamp sockets for ease of relamping and to reduce lamps disconnecting due to vibration or incidental contact. Luminaire is bi-national listed (UL 1598 and CSA C22.2 No. 250.0-00) and is suitable for damp locations.

Mounting - The luminaire may be suspended by chain, monopoint or cable with appropriate accessories.

- Accessories are available.

Lamps - Factory installed lamps are available in various CRI ratings, temperature colors and rated life.

Warranty - Standard 1-year warranty for the fixture. Ballasts carry manufacturer warranties of 3-5 years, depending on the application.



Catalog Logic

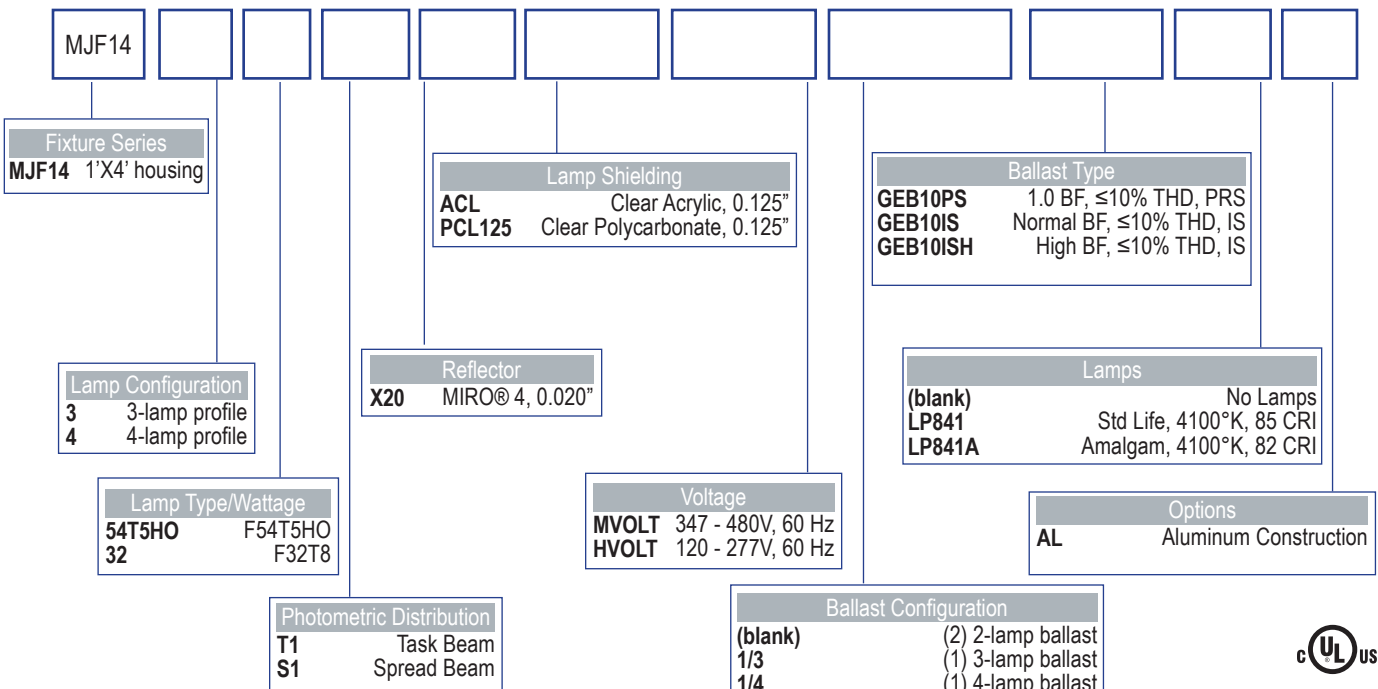

MMJF164T5LSD30HB7701





Applications

The MJF14 series fluorescent luminaire provides significant energy savings, improved color recognition, and longer maintenance cycles for cold storage facilities. Improvements in lamp and ballast technology combined with MetalOptic's engineering experience have come together to create a better alternative to HID systems for low temperature environments. The luminaire is designed for cold storage areas -20° F / -29° C.

Dimensions

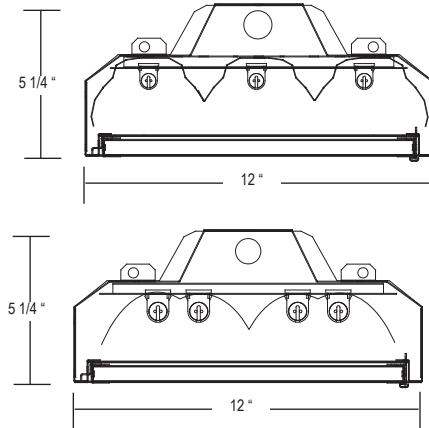
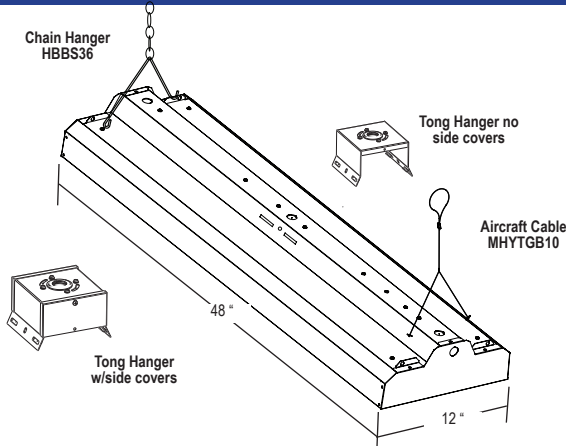

Features

- The MJF14 1'x4' series is especially suited for aisles up to 25' mounting height using the task beam optics. The spread beam optics are designed for loading dock and staging areas with mounting heights to 18 feet.
- Specular aluminum reflectors are precision formed of 95% reflectance Alnanod MIRO®4.
 - Luminaire designs are engineered for high light output and tested in an in-house thermal chamber for cold environments down to -20°F/-29°C ambient temperatures.
 - Housing and door are double gasketed to contain lamp heat energy for maximum lumen output at low temperatures.
 - Luminaire housing is a powder coated after fabrication standard to seal all exposed steel parts for corrosion protection.
 - Mounting is accomplished with two-point chain or aircraft cable hangers connected to external integral housing brackets.
 - Motion sensor control options are available as an externally mounted accessory.
 - Integral emergency battery back-up options are available for most models.

Additional Options (installed on fixture)

- Reloc
- Motion Sensor
- Cord Sets
- Fusing

Accessories (order separately)

- Chain Hanger, 36" **HBBS36***
- Aircraft Cable, w/hook, 18" legs, 10' **MHYHKB10***
- Aircraft Cable, w/toggle, 18" legs, 10' **MHYTGB10***
- Monopoint Hanger, w/ 3/4" KO **THSDZ3**
- Monopoint Hanger, w/ 3/4" hub **THSDZ3HB**
- Monopoint Hanger, w/ male fixture hook **THSDZ3HBHKM**
- Side covers for Monopoint Hangers **THSDZ3SK**

Photometrics

SC Across Definitions:

Focus = < 0.9 Spacing Criterion (SC)

Spread = 1.4 to 1.8 Spacing Criterion (SC)

Task = 0.9 to 1.2 Spacing Criterion (SC)

Broad = > 1.8 Spacing Criterion (SC)

Normal = 1.2 to 1.4 Spacing Criterion

Consult Factory for Photometrics

